



VELA Industrial

ELECTRO-HYDRAULIC BARRIER FOR PARKINGS AND INDUSTRIAL ENTRANCES WITH OPENING TIME FROM 8 SEC. TO 12 SEC.;
MAX BEAM LENGTH 7,5 MT; HYDRAULIC SLOWDOWN IN OPENING AND CLOSING.

Silent & Safe

The Vela Industrial hydraulic power units contains the electric motor, fluid pump and valve/distribution block. A double action hydraulic piston drives the spring balanced beam assembly.

The beam hydraulically locks in the open and closed position

Manual Release

In case of a power failure: The unit can be put on to manual operation using the special key supplied.



OPERATOR SPECIFICATION

Supply voltage	230 Vac ± 5%
Motor power	230W
Motor current	1.1 A
Pump capacity	2 lt.
Thermal protection intervention	130°C
Operating temperature	-20°C +55°C
Opening times	8 12 sec
Beam length	7.5 mt max
Cabinet finish	verniciatura a polvere
Weight with oil	73 Kg
Oil quantity	1.5 lt.
Protection class	IP 55
Certification	CE

DESCRIPTION

COD

PUMP lt.

PAINTED VELA OPERATOR AND ACCESSORIES WITH BALANCING SPRING AND BUILT-IN ELECTRONIC CONTROL UNIT FOR BEAM OF 5 MT	SX DX	11701020 11701005	2 2
PAINTED VELA OPERATOR AND ACCESSORIES WITH BALANCING SPRING AND BUILT-IN ELECTRONIC CONTROL UNIT FOR BEAM OF 6 MT	SX DX	11701025 11701010	2 2
PAINTED VELA OPERATOR AND ACCESSORIES WITH BALANCING SPRING AND BUILT-IN ELECTRONIC CONTROL UNIT FOR BEAM OF 7 MT	SX DX	11701030 11701015	2 2
PAINTED VELA OPERATOR AND ACCESSORIES WITH BALANCING SPRING AND BUILT-IN ELECTRONIC CONTROL UNIT FOR BEAM OF 7,5 MT	SX DX	11701040 11701035	2 2

**ELECTRONIC
CONTROL UNIT FOR
VELA Industrial Cod. 23010006**

NOTE: On request we can supply the inox steel casing.



BEAMS

DESCRIPTION	COD	DESCRIPTION	COD
RECTANGULAR RIGID BEAM 5 MT (BEAM MT 4,50 + SUPPORT)	11905005	RECTANGULAR RIGID BEAM 7 MT (BEAM MT 6,50 + SUPPORT)	11905015
RECTANGULAR RIGID BEAM 6 MT (BEAM MT 5,50 + SUPPORT)	11905010	RECTANGULAR RIGID BEAM 7,5 MT (BEAM MT 7 + SUPPORT)	11905020



Typical Installation

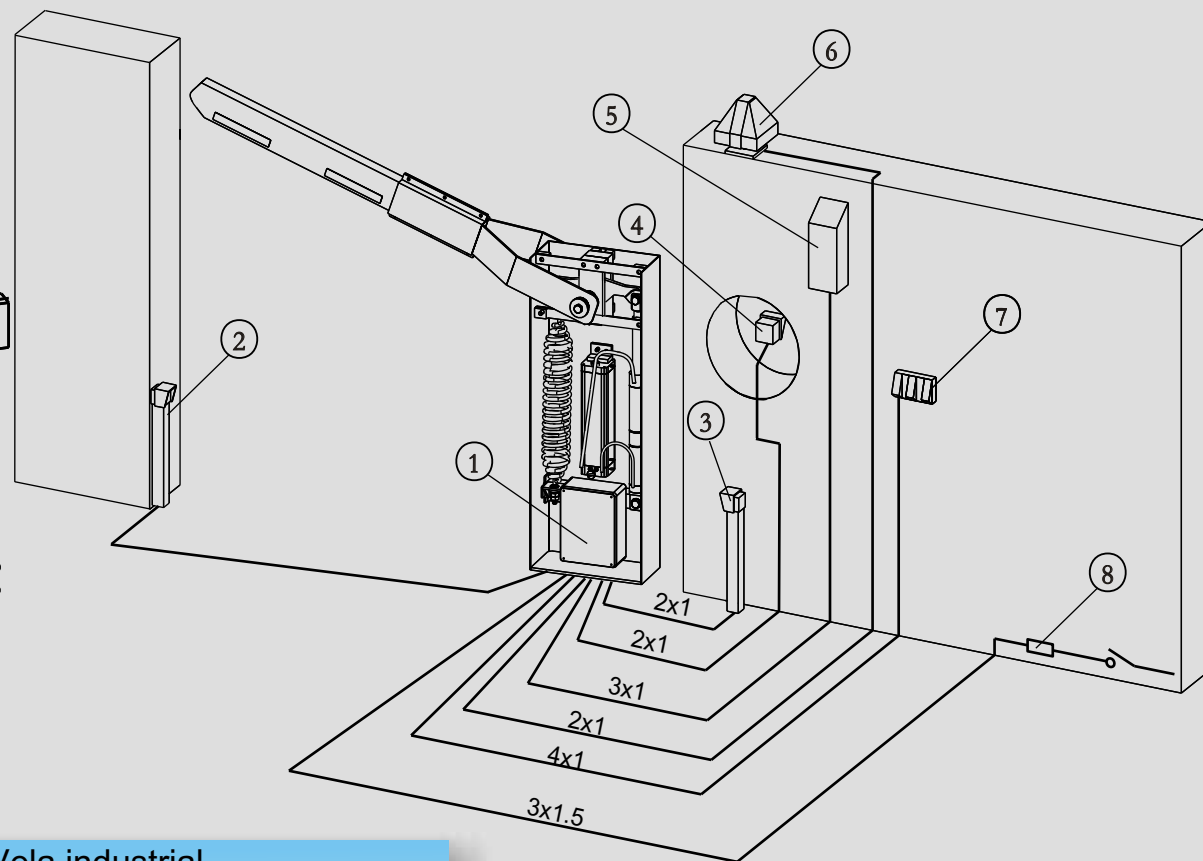
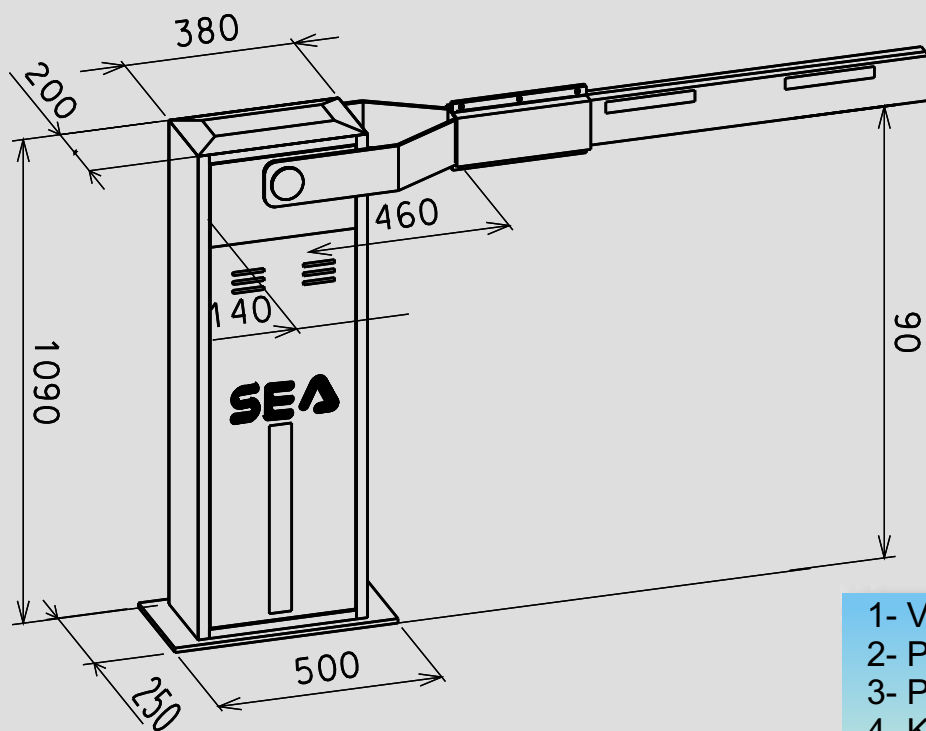

- 1- Vela industrial
- 2- Photocell Rx
- 3- Photocell Tx
- 4- Keyswitch
- 5- Radio receiver
- 6- Warning light
- 7- Push button panel for internal
- 8- Differential switch